

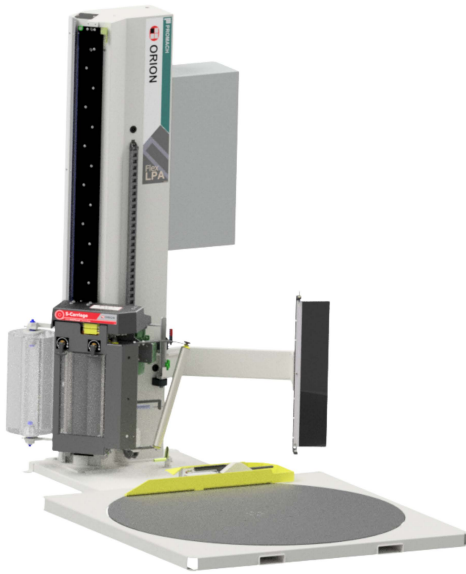

R&E

ROBOTICS &  
END OF LINE

## ORION FLEX LPA & FLEX HPA AUTOMATIC TURNTABLE PALLET WRAPPING SYSTEMS



### Performs the entire film wrap cycle automatically

Simply place the pallet load on the machine and pull a lanyard switch while backing away. The Flex automatic machines perform the entire wrap cycle without the operator dealing with the film tail at the beginning or end of the cycle — significantly impacting your efficiency by freeing operators to work on other tasks while the machine is wrapping.

LPA & HPA features include heavy-duty steel framework and turntable support system, AC motors, and a belt-driven carriage lift. And, the LPA and HPA are now equipped with the industry leading S-Carriage InstaThread™ film delivery system. The S-Carriage provides a standard 260% film-saving pre-stretch, and is the most versatile carriage for a wide range of film types and gauges. Plus, the S-Carriage is designed for quick, safe, and easy film loading and changeover.

#### LPA SPECIFIC FEATURES:

- 63" diameter turntable for loads up to 50" x 50"
- Max load height 80"- standard, 110"- optional
- Load with a pallet jack, electric walkie, or forklift
- Full surround deck for easier loading
- Precision ring bearing turntable support, with heavy-duty casters for additional support

#### GENERAL FEATURES:

- Automatic Wrap Cycle for Operator Efficiency
- 7" IntelVue color, HD touch screen HMI
- 15 RPM variable speed w. "soft start"
- 6,000 lb. maximum load weight capacity - Orion's universal base uses a robust ring bearing design
- Film saving 260% powered film pre-stretch
- Automatic force to load for even film tension
- AC/VFD motors reduce maintenance
- Forklift portable from front or rear
- Structural steel frame for durability

#### HPA SPECIFIC FEATURES:

- 48" x 48" turntable for loads up to 50" x 50"
- Precision turntable with heavy-duty ring bearings
- Octagonal turntable for easy forklift loading
- Side facing carriage for easy film loading

### TYPICAL PRODUCT SPECIFICATIONS

<b>Product Type</b>	Turntable automatic stretch wrappers
<b>Speed</b>	15 RPM
<b>Display</b>	7" color IntelliVue HMI
<b>Frame</b>	Heavy-duty welded tubular steel
<b>Electrical Requirements</b>	115/1/60, 20 Amp electrical service (Not suitable for GFCI)
<b>Air Requirements</b>	3 CFM @ 80 PSI

### SHIPPING WEIGHT & DIMENSIONS

<b>LPA</b>	80" Mast Ships as 1 pc.	2,550 lbs.	6' x 8' x 8.5'
	110" Mast Ships as 2 pcs.	2,650 lbs.	base 6' x 8' x 4' tower 5' x 11' x 4.5'
<b>HPA</b>	80" Mast Ships as 1 pc.	1,750 lbs.	6' x 8' x 8.5'
	110" Mast Ships as 2 pcs.	1,850 lbs.	base 4' x 8' x 4' tower 5' x 11' x 4.5'

### MACHINE DRAWINGS

Flex LPA - Dimensions - Inches

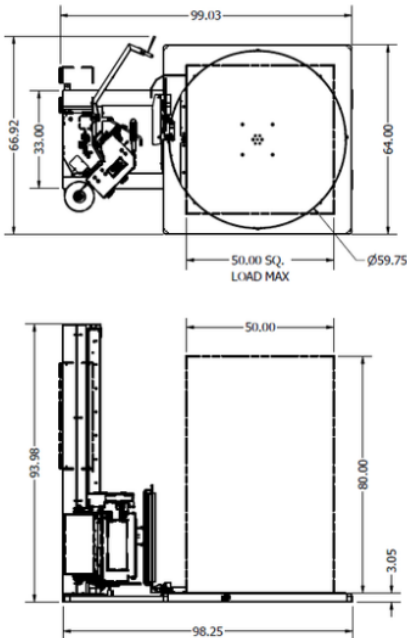

Flex HPA - Dimensions - Inches

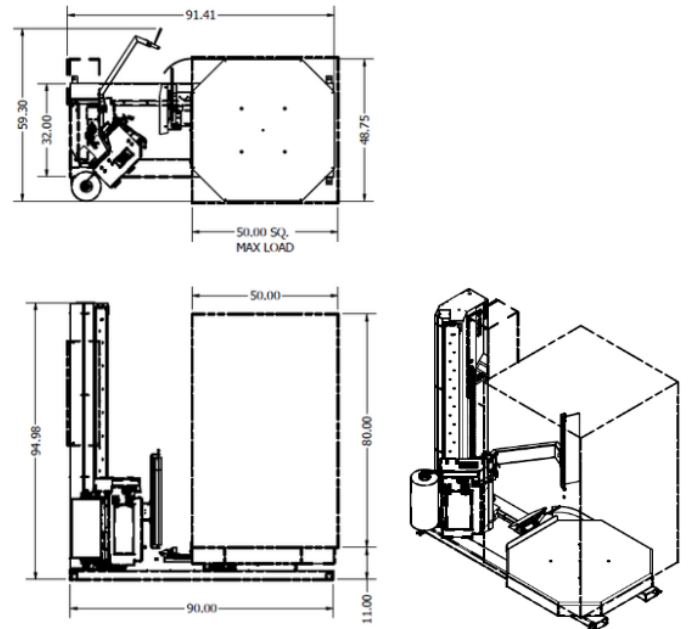

### STANDARD FEATURES

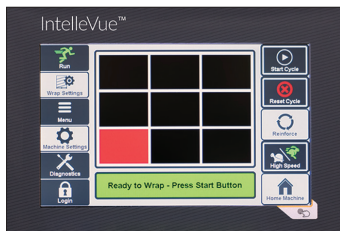

**7" IntelliVue HMI**  
User-friendly, password protected touch screen controls with up to 9 different wrap recipes.



**Film Carriage Pre-stretch**  
The S-Carriage InstaThread Film Delivery System elongates film at a standard rate of 260%, providing the most secure loads at the lowest cost.

### OPTIONS

- Integrated scale or platform scale
- Extended mast - 110"
- Load height photocell regular or specialized for dark/opaque loads
- 30" film carriage
- Wireless 3-button remote
- Air compressor unit
- Bolt-on film clap guard mounted on the base frame, painted safety yellow (LPA)
- Forklift wheel stops